

SAGE SIG SPECIFICATIONS

INTEGRAL STYLE GENERAL PURPOSE IN-LINE MASS FLOWMETER

Flow Meter is thermal dispersion type, utilizing constant temperature difference method of measuring Gas Mass Flow Rate. It contains two reference grade platinum RTD sensors clad in a protective 316 SS sheath. Features direct Mass Flow for gases, wide rangeability, low pressure drop, very low end sensitivity, and no moving parts.

Flow Meter is microprocessor based, does not have any potentiometers, and has RS232 communications with accompanying menu driven software (Sage VIP). Flow Meter is powered by 24 VDC or 115 VAC/ 230 VAC. The power dissipation is under 8 watts (e.g. under 350 ma at 24 VDC).

Electronics is Integral Style, with NEMA 4X Windowed Enclosure, Local Display and Touch Screen Display Keypad. The Display is a back-lit LCD with two lines of information: Mass Flow Rate on top line; and Totalized Flow and Temperature on bottom line. The Touch Screen Keypad has 4-buttons (accessible without needing to remove the cover) and provides a convenient means to interface with an extensive menuing system. The electronics has a 4 to 20 ma output proportional to Mass Flow Rate as well as a 4 to 20 ma output proportional to Temperature. Outputs are opto-isolated. In addition, two dry contact relays are provided that can be configured for pulsed outputs of Totalized Flow, or Trip High, Trip Low, and other functions.

Flow Element is In-Line Style consisting of a choice of 316 Stainless Steel Schedule 40 Flow Bodies sized from 1/4" x 6" long to 4" x 12" long. Male NPT ends are standard, with flanged ends, tube, or butt weld optionally available. Note 3" and 4" Flow Bodies have flanged ends as standard.

Calibration Self Check: Flow Meter has built in diagnostics – the menuing system has provisions to check the sensor's operation by accessing the sensor's output, and comparing it to the original reported "zero flow" value noted on last line of meter's Certificate of Conformance.

Accuracy is +/- 0.5% of Full Scale +/- 1% of Reading with a turn-down of up to 1000 to 1. Repeatability will be 0.2%. The Flow Meter is Sage Metering, Inc. SIG Series.

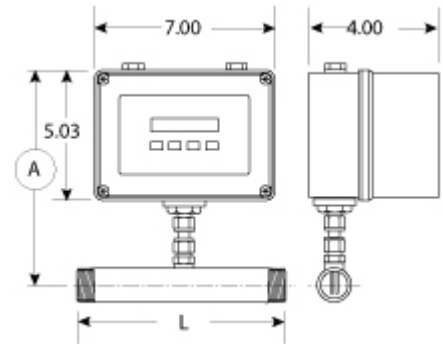

Models

Pipe Size x Flow Body Length ¹ or Flange (Face-to-Face)	In-Line Models	Max Full Scale (SCFM) ^{2, 3}
1/4" x 6"	SIG-025	8
3/8" x 6"	SIG-030	15
1/2" x 7"	SIG-050	30
3/4" x 7"	SIG-075	140
1" x 8"	SIG-100	200
1-1/4" x 10"	SIG-125	300
1-1/2" x 12"	SIG-150	470
2" x 12"	SIG-200	820
2-1/2" x 12"	SIG-250	1000
3" x 12"	SIG-300	1750
4" x 12"	SIG-400	3150

1 - Flow Conditioning built in to Flow Meter pipe sizes 3/4" and up

2 - Max Full Scale available for many gases, such as pressurized Air or Nitrogen. Some gases such as Hydrogen may be limited. Contact Sage for details. Calibrations above 500 SCFM may be extrapolated

3 - SCFM = Standard Cubic Feet Per Minute. 1 SCFM = 1.7 NCMH. Sage standard conditions for calibration are 70°F and 29.92" Hg. Note, Max Full Scale is based on a maximum Velocity of 35,000 Standard Feet Per Minute (SFPM)

Specifications

	General
Function	Microprocessor-based In-Line Mass Flow Meters for gases
Flow Element	Constant Temperature Thermal Mass Flow Element consists of two 316 SS clad platinum-wound RTDs
Flow Rate Output Signal	4-20 ma isolated output linearly proportional to mass flow rate
Temperature Output Signal	4-20mA isolated linear temperature signal from 40°F to 200°F. (i.e. this product has both a flow and temperature output)
Power	24 VDC with current dissipation of less than 350 ma with backlight on (less than 250 ma with backlight off), or 115VAC/230 VAC
Communication	RS232 Communication and Menuing Software (Sage VIP)
Sensor Drive Circuit	Proprietary Sensor Drive Circuit provides enhanced flow signal stability and insensitivity to process temperature changes
Display / Keypad	2 Line 2 x 16 large format back-lit display with standard 4-Button Keypad. Flow Rate (top line), Total and Temperature (bottom line)
Menu Navigation	4-Button Touch Screen Display Keypad and RS232 with navigational software (Sage VIP) standard. Touch Screen Display technology (the cover does not need to be opened to access Menuing System)
Multiple Channel Capability	Up to four totally independent calibrations. Calibrate for four different gases, different sensitivities, and/or different configurations (Channels A–D). Channels can be keypad, laptop or externally selectable (via contact closures)

	Flow Range / Sizes
Units of Measurement	Flow—SCFM, SCFH, SCFD, SCCM, NCMM, NCMH, KG/S, KG/M, KG/H, KG/D, LBS/S, LBS/M, LBS/H,LBS/D, SLPM, SLPH; Temperature—°C and °F
In-Line Meters	Full Scale up to 3150 SCFM (4" Flow Meter). Resolve as low as .003 SCFM (1/4" Flow Meter).Male NPT fittings standard. 150# and 300# flanged ends optional
	Performance
Standard Flow Accuracy	+/-1% of Reading +0.5% of Full Scale
Repeatability	0.2% of Full Scale
Turndown	Up to 1000:1
Calibration	Sage Metering's National Institute of Standards Traceable (NIST) calibration facility
Gas Temperature	Std.: -40°F to 200°F (-40°C to 93°C); HT01: 200°F to 350°F (93°C to 177°C)
Integral Enclosure Temperature	0° to 150°F (-18°C to 65°C). Contact Sage for lower temperature ranges
Pressure Rating	500 psig (1000 psig optional)
Response Time	1 second (each time constant) for flow change
Relays	Two dry contact Relays suitable for Pulsed Outputs of Totalized Flow or configurable to Trip High or Trip Low
Wetted Parts	316L Stainless Steel for Flow Bodies, Sensor Flow Elements and Flow Conditioners. Hastelloy (recommended for Chlorine Gas) and other materials optional
Limited Warranty	Sage Metering's Series of Thermal Mass Flow Meters are warranted against faulty materials or workmanship for one year from the date of delivery to the buyer. After issuance of a Return Meter Authorization (RMA) by Sage, and upon receipt of the defective meter, Sage will either repair or replace the defective meter at its sole option and at no cost to the purchaser