



## Features

- 15 sizes from 15 to 500mm (½ to 20")
- Wide variety of process connections
  - BSP / NPT male to 50mm (2")
  - ANSI or DIN flanges
- Pressure to 250 bar (3675 psi)
- Standard range of -50 to 120°C (-58 to 250°F)
- Long life tungsten carbide bearings
- +/- 0.5% linearity (10:1 turndown)

## Options

- +/- 0.15% linearity (10:1 turndown) for sizes 100mm (4") and larger
- Explosionproof or intrinsically safe pickoffs
- Integral preamplifier, frequency to current converter (4-20 mA output) or flowrate / totaliser with various outputs.
- Integral or remote self powered flow rate-totaliser with scaled pulse, analog and flow alarm outputs ( see separate data sheet )
- Integral or remote high speed preset batch controller ( see separate data sheet )

# Turbopulse Industrial Series Turbine Flowmeters



## Overview

Turbopulse turbine flowmeters are precise, reliable and robust units for the volumetric flow measurement of clean low viscosity liquids.

Stainless steel construction with tungsten carbide bearings provides long life with a wide range of aggressive and non-lubricating liquids in petrochemical and general industrial applications.

Fifteen sizes cover flows from 0.11 to 7000 m<sup>3</sup>/hr (0.5 to 30000 USGPM) with +/- 0.5% linearity. Enhanced linearity is available in larger sizes where custody transfer performance is required.

The standard pick-off coil is supplied with either a military style plug or a junction box with terminal strip.

Integral preamplifiers are available for harsh environments, to extend transmission distance or to interface with secondary instruments that require a conditioned signal input.

An integral RT100 series flowrate totaliser is optionally available to provide local indication with 4-20mA and Hi/Lo flow alarm outputs and/or scaleable pulse output.

## Calibration

Sizes 25mm (1") and larger are calibrated on positive displacement prover loops in accordance with current API standards.

For each meter size calibration is performed at five points across the nominal flow range to ensure optimum performance in every application.

Data Sheet No. SLTP000-1001

QUALITY AND SIMPLICITY IN FLOW MEASUREMENT

# DIMENSIONS

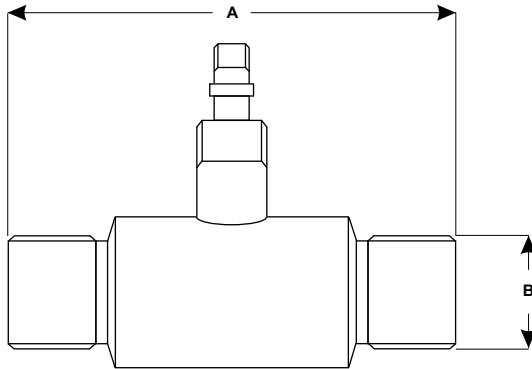

MODEL NUMBER	'A'	'B'
TP010	64mm (2.5")	½" (15mm) BSP or NPT
TP012	64mm (2.5")	¾" (20mm) BSP or NPT
TP015	64mm (2.5")	¾" (20mm) BSP or NPT
TP020	83mm (3.3")	¾" (20mm) BSP or NPT
TP025	89mm (3.5")	1" (25mm) BSP or NPT
TP040	115mm (4.5")	1½" (40mm) BSP or NPT
TP050	133mm (5.2")	2" (50mm) BSP or NPT

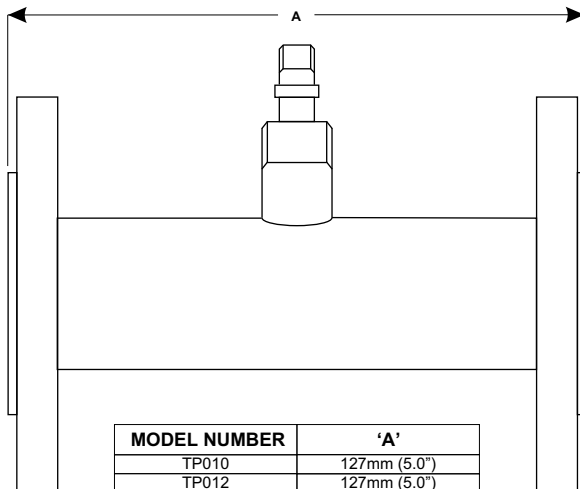
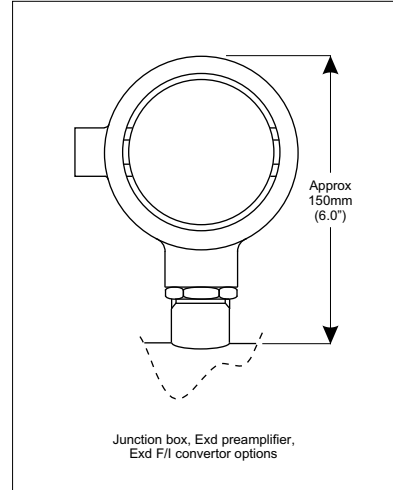

MODEL NUMBER	'A'
TP010	127mm (5.0")
TP012	127mm (5.0")
TP015	127mm (5.0")
TP020	140mm (5.5")
TP025	152mm (6.0")
TP040	178mm (7.0")
TP050	197mm (7.8")
TP080	254mm (10.0")
TP100	356mm (14.0")
TP150	368mm (14.5")
TP200	457mm (18.0")
TP250	457mm (18.0")
TP300	457mm (18.0")
TP400	610mm (24.0")
TP500	610mm (24.0")

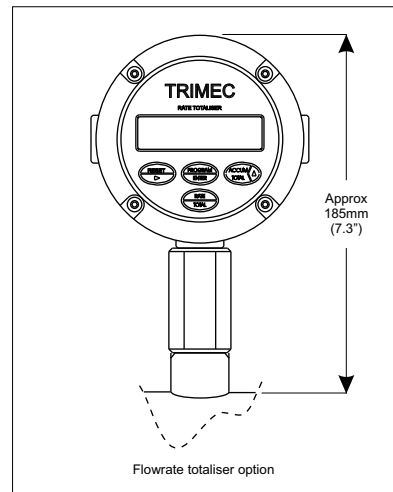

Note: All dimensions are nominal

## SPECIFICATIONS

Connection Size	15 models from 15 to 500mm (1/2 to 20", DN15 to DN500) (see ordering information for available sizes)
Process Connections	BSP or NPT male threads to 50mm (2", DN50) All sizes flanged to ANSI or DIN specifications in carbon steel, 304 or 316 stainless steel, other flange types on request
Nominal Flow Range*	0.11 - 1.1 m <sup>3</sup> /hr to 700 - 7000 m <sup>3</sup> /hr (0.5 - 5 USGPM to 3000 - 30000 USGPM) (see ordering information for flow range of each model) <i>* For non lubricating liquids, the maximum flow should be reduced by 25%</i>
Viscosity Range	10 cSt recommended maximum to maintain linear range
Linearity	+/- 0.5% over 10:1 range as standard, +/- 0.15% over 10:1 range optional for sizes 100mm (4", DN100) and larger
Repeatability	+/- 0.02 to 0.05% under steady flow conditions
Temperature Range	-50 to 120°C (-58 to 250°F) as standard, optionally to 240°C (465°F)
Maximum Pressure	Threaded versions to 250 bar (3675 psi), flanged meters according to flange specification
Pressure Drop	Approximately 0.28 bar (4 psi) at maximum flow (SG=1, viscosity =1 cSt)
Body Material	304 stainless steel (1.4301) standard, 316 stainless steel (1.4401) optional
Rotor Material	ANSI 431 or SS 430/410 where cast
Bearing Support Material	304 stainless steel (1.4301) standard, 316 stainless steel (1.4401) optional
Bearings	Tungsten carbide sleeve
Output	Reluctance type pick-off coil (20 mV P/P minimum), max. 50m transmission.
Preamplifier Output	Two wire 4-20mA current pulse (12-28 VDC), max. 3000m transmission

### Remote Mounting Options for 100 Series Electronics

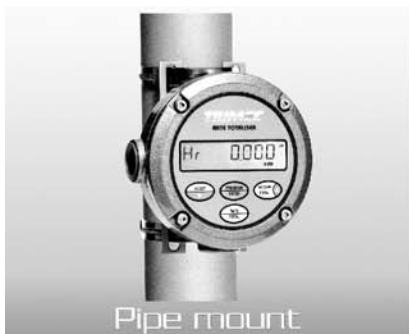

IN THE INTERESTS OF PRODUCT DEVELOPMENT TRIMEC RESERVES THE RIGHT TO ALTER THE DESIGN AND SPECIFICATIONS WITHOUT NOTICE ©

QUALITY AND SIMPLICITY IN FLOW MEASUREMENT

# ORDERING INFORMATION

TP	CONNECTION SIZE		FLOW RANGE	
	DN (mm)	inches	m <sup>3</sup> /hr	USGPM
010	15	1/2"	0.11 - 1.1	0.5 - 5
012	20	3/4"	0.22 - 2.2	0.9 - 9
015	20	3/4"	0.4 - 4	1.8 - 18
020	20	3/4"	0.8 - 8	3.6 - 36
025	25	1"	1.6 - 16	7 - 70
040	40	1 1/2"	3.4 - 34	15 - 150
050	50	2"	6.8 - 68	30 - 300
080	80	3"	13.5 - 135	60 - 600
100	100	4"	27 - 270	120 - 1200
150	150	6"	55 - 550	240 - 2400
200	200	8"	110 - 1100	480 - 4800
250	250	10"	190 - 1900	840 - 8400
300	300	12"	270 - 2700	1200 - 12000
400	400	16"	400 - 4000	1800 - 18000
500	500	20"	700 - 7000	3000 - 30000

## BODY MATERIAL

S	304 stainless steel
V	316 stainless steel

## PROCESS

1	BSPP threaded
2	NPT threaded
3	* Tri-clamp ferrules (body material 316ss [ V ] only)
4	ANSI 150 RF flanges
5	ANSI 300 RF flanges
6	PN10 flanges
7	PN16 flanges
8	PN25 flanges
9	Special

## PROCESS CONNECTION MATERIAL

T	Threaded stainless steel as per body material
S	304 stainless steel flanges
V	316 stainless steel flanges or Tri-clamp ferrules
C	Carbon steel flanges

## NO. OF PICK-OFFS

1	One
2	Two, 90° Electrical Offset

## PICK-OFF STYLE

- 1	MS connector
- 2	Flying lead

## PICK-OFF TYPE

1	Standard (120°C, 250°F)
2	High temperature (240°C, 465°F)
3	Intrinsically safe (85°C, 170°F)
4	Integral pre-amplifier (60°C, 140°F)

## LINEARITY

1	+/- 0.5% (standard)
2	+/- 0.15%

## OPTIONS

00	None
JB	Exd junction box
PA	Exd preamplifier
FI	Exd frequency to current (F/I) convertor, 4-20 mA output
R1	RT11 rate / totaliser (scaleable pulse output)
R2	RT12 rate / totaliser (RT11 + 4-20 mA output & alarms)
EB	EB10 High Speed Preset Batch Controller

I N D U S T R I E S

## HEAD OFFICE & FACTORY

2/1 KOONYA CIRCUIT,  
TAREN POINT,  
SYDNEY, N.S.W.  
AUSTRALIA

Tel : +61 2 9540 4433  
Fax : +61 2 9525 9411  
Email : sales@trimecind.com.au  
Website : www.trimecind.com

## TRIMEC EUROPE LTD

Floor 3, 5A Boltro Road  
HAYWARDS HEATH  
WEST SUSSEX  
UNITED KINGDOM RH16 1BP

Tel : +44 144 441 7880  
Fax : +44 144 441 7668  
Website : www.trimecind.com

## TRIMEC USA LLC

2603 CAMINO RAMON, 2nd Fl.  
SAN RAMON,  
CALIFORNIA 94583  
U.S.A.

Tel : 925-242-2510  
Fax : 925-736-8497  
Email : schriefer@trimecusa.com  
Website : www.trimecind.com

QUALITY AND SIMPLICITY IN FLOW MEASUREMENT